

# KM715/10(25)

ENCLOSED TYPE

\* KM715/10 : 0~2m 미만 사용시 권장  
\* KM715/20 : 2~4m 사용시 권장

- Material : Engineering Plastic with Glass Fiber +  $\alpha$
- Speed : 3 m/sec
- Temperature : -25 ~ 125°C

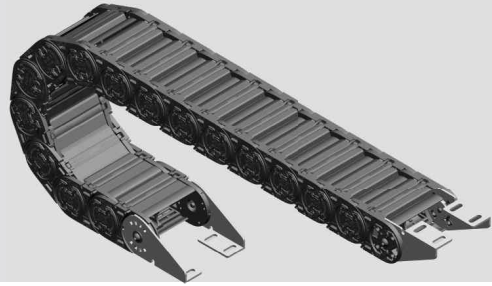

## Structure

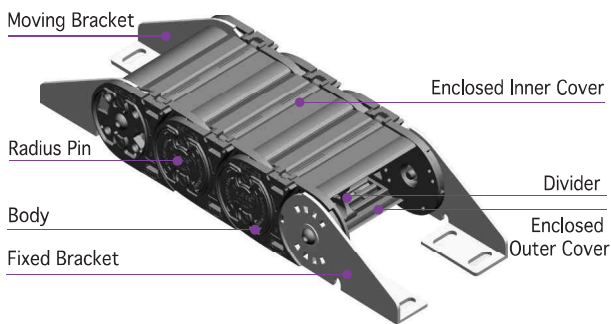

## Load Diagrams Self-Supporting Length

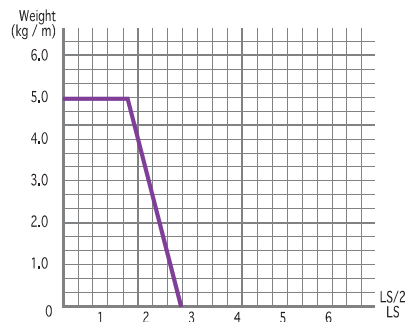

## End Bracket

### Fixed Bracket

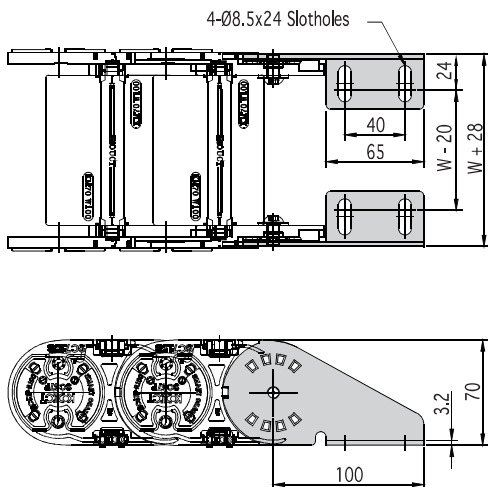

### Moving Bracket

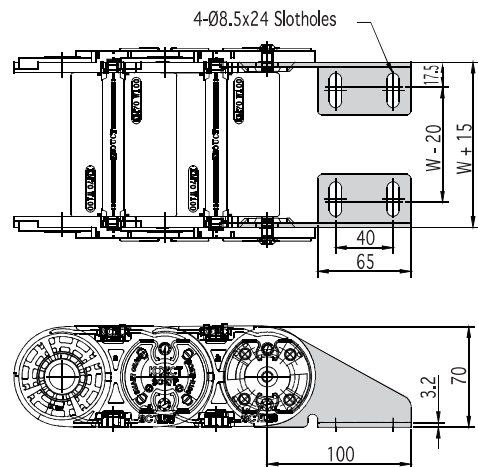

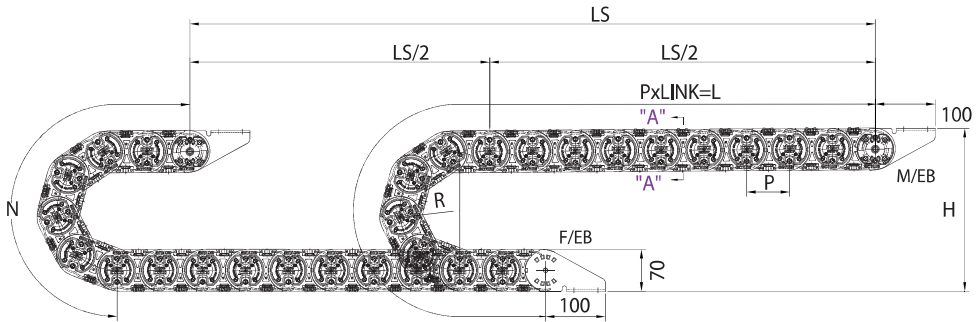

$$L = \frac{LS}{2} + N$$

LS: Total Machine Travel, L: Length, N: Safety Length+πr,  
 H: Height, P: Pitch, M/EB: Moving End Bracket, F/EB: Fixed End Bracket

Section A-A

Divider

\* Separator: Ø6(Aluminum)

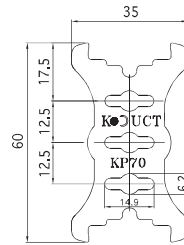
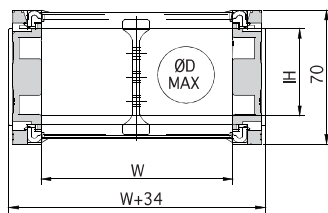

Specification

TYPE	W mm(inch)	Radius mm(inch)	Pitch mm(inch)	IH mm(inch)	ØD MAX	Height mm(inch)	N mm(inch)	DVDR (ea)	1M (kg)	EB Set (kg)
	75 (2.952)	100 (3.937)		37 (1.456)	Ø16	270 (10.629)	529 (20.826)	0	3.06	
		125 (4.921)		41 (1.614)	Ø20	320 (12.598)	607 (23.897)			
KM715/ 10(25)	100 (3.937)	150 (5.906)	71.5 (2.814)	43 (1.692)	Ø25	370 (14.566)	686 (27.007)	1	3.38	0.75
		200 (7.874)		44 (1.732)	Ø33	470 (18.503)	842 (33.149)			
		120 (4.724)		250 (9.842)	45 (1.771)	Ø41	570 (22.440)			

\* 1inch = 25.4mm